

# VAS22-S80E-0.6-WSC5.31T/TXL

## – Extension Cable

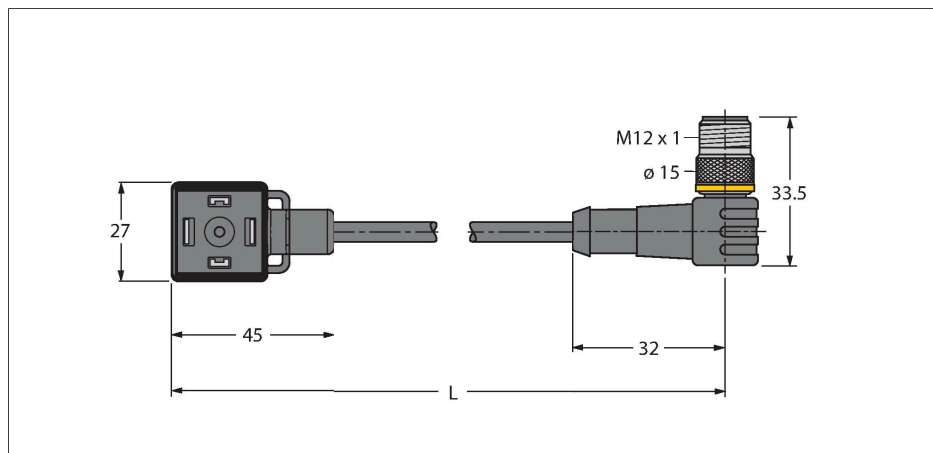

### Features



- 2-pin + PE
- Design according to the DIN EN 175301-803
- RoHS-compliant
- Protection class: IP65, IP67, IP68
- Protective component: Transil diode
- M12 male, angled, 2-pin + PE
- Jacket material: PUR
- Jacket color: black
- Suitable for drag chain use
- Resistant to chemicals and oils
- UV and ozone resistance
- Flame retardant
- Free from halogen, silicone, PVC and LABS
- Cable length: 0.6 m

### Technical data

Type	VAS22-S80E-0.6-WSC5.31T/TXL
ID	6606793
Number of Pins	2+PE, PE bridged
Protective component	Transil diode
Display switch state	LED, Yellow/Yellow
Protection class	IP65, IP67, IP68
Connector B	Male, M12 × 1, Angled
Number of pins	2+PE
Contacts	Metal, CuZn, Gold-plated
Contact carriers	Plastic, TPU, Black
Connector body	Plastic, TPU, Black
Coupling nut/retaining screw	Brass, CuZn, Nickel-plated
Tightening torque	0.8 ... 1 Nm
Mechanical life	> 100 Mating cycles
Pollution degree	3
Protection class	IP67, IP69K, Only when screwed together
Cable diameter	Ø 5.2 mm ±0.20
Cable length	0.6 m
Cable jacket	PUR, Black
Core insulation	PP
Core cross-section	3 x 0.75 mm <sup>2</sup>
Arrangement of strands	42 x 0.1 mm
Core colors	BN, BU, GNYE
<b>Electrical properties at +20 °C</b>	
Rated voltage	24 V
Test voltage	2000 V
Current	4 A

### Contact assignment

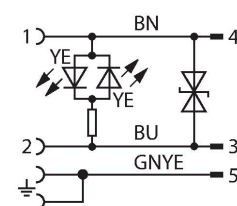
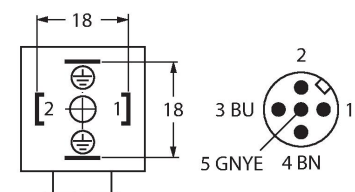

## Technical data

Insulation resistance	> 1 MΩ/km
forward resistance	max. 57 Ω/km
<b>Mechanical and chemical properties</b>	
Max. tensile strength (static)	≤ 50 N/mm <sup>2</sup>
Max. tensile strength (dynamic)	≤ 20 N/mm <sup>2</sup>
Bending radius (stationary installation)	≥ 5 x Ø
Bending radius (flexible use)	≥ 10 x Ø
Bending cycles	≥ 3 million
Admissible acceleration	max. 5 m/s <sup>2</sup>
Admissible travel path, horizontal	5 m (at 5 m/s <sup>2</sup> )
Admissible travel path, vertical	2 m (at 5 m/s <sup>2</sup> )
Admissible traversing speed	3.3 m/s
Torsional stress	± 180 °/m
Ambient temperature range (stationary)	-40 °C...+80 °C
Ambient temperature range (In motion)	-30 °C...+90 °C
Ambient temperature during drag chain operation	-25 °C...+60 °C
Approvals	CE UKCA