

Accessories for Fieldbus Systems

male flange with strands, front-mounted

EC-FSDW4.54-0.5/16

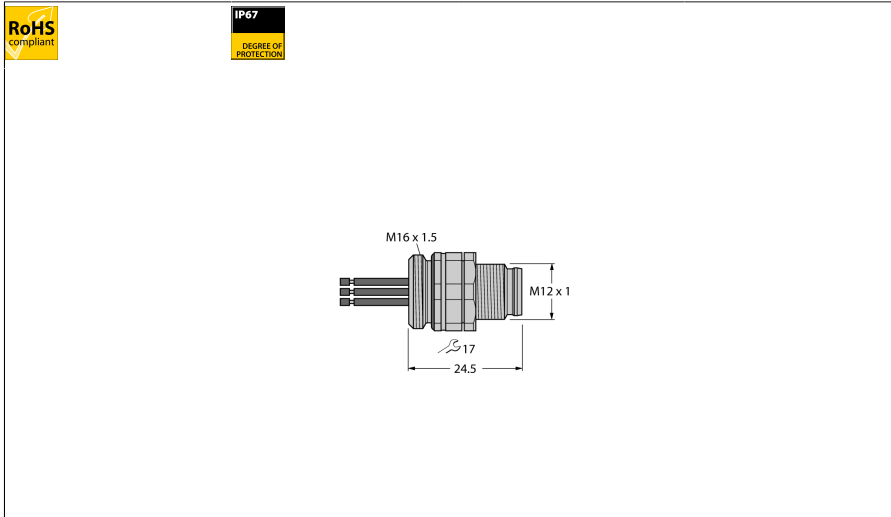

- Design: M12 male connector
- Reverse-keyed, 5-pin, stranded wire 0.5 m
- Front-mounted
- Rotatable contact body
- M16 × 1.5 metric screw-in thread
- For use in PROFIBUS-DP applications

Pin Assignment

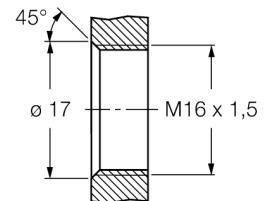
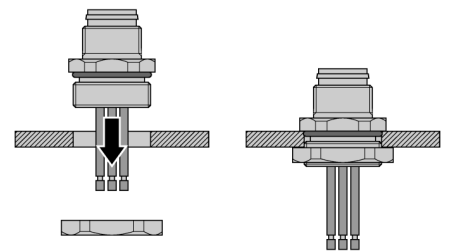
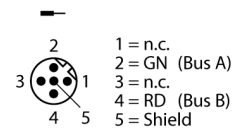

Type	EC-FSDW4.54-0.5/16
ID	6935755
Connector A	Male, M12 × 1, With Stranded Wire, B-coded
Number of Pins	5
Contact carriers	Plastic, TPU, Black
Flange housing	Brass, CuZn, Nickel-plated
Mounting type	front panel mounting
Screw-in thread	M16 × 1.5
Connection mode	Wire connection
Mechanical lifespan	> 100 Mating cycles
Pollution degree	3
Protection class	IP67, (screwed together)
Network protocol	PROFIBUS-DP
Cable length	0.5 m m
Cable jacket	PVC
Core insulation	PVC
Core cross-section	5 x 0.34 mm ²
Arrangement of strands	7 x 0.25mm
Core colors	BN, GN, BU, RD, GY
Electrical properties at +20 °C	
Rated voltage	60VV
Current	4AA
Insulation resistance	≥ 10 ⁸ Ω
forward resistance	≤ 5 mΩ
Mechanical and chemical properties	
Ambient temperature range (stationary)	-30°C...+90°C°C