

FS54PL-2/M16

M12 Power Flange – Front-mounted

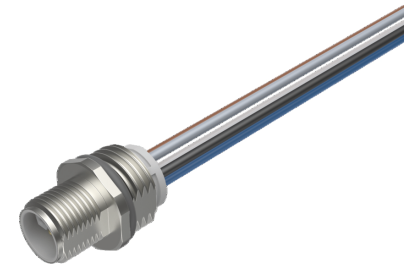
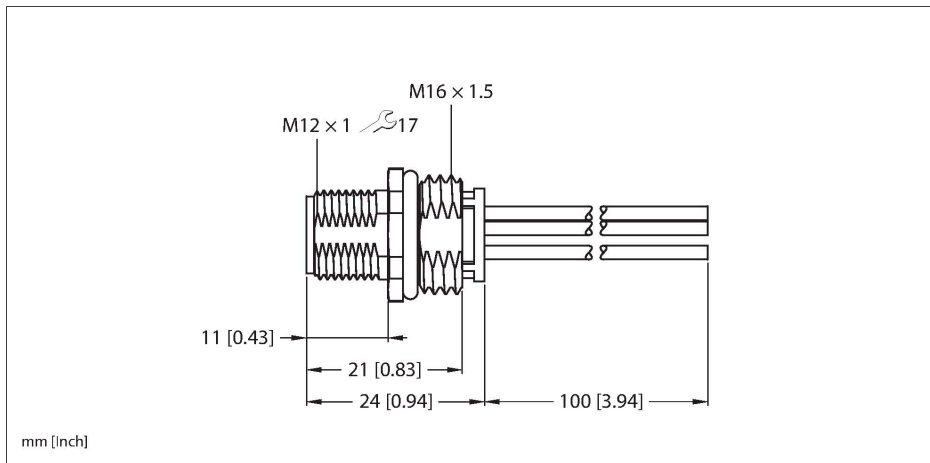

Technical data

Type	FS54PL-2/M16
ID	100003948
Connector A	Male, M12 × 1, L-coded
Design specification	acc. to IEC 61076-2-111
Number of Pins	4+FE
Contacts	Brass, CuZn, Gold-plated
Contact carriers	Plastic, PA, Black
Seal	Plastic
Flange housing	Brass, CuZn, Nickel-plated
Tightening torque (range)	0.4 ... 1 Nm (observe max. torque of mating connector!)
Mounting type	front panel mounting
Screw-in thread seal	O-ring, NBR
Screw-in thread	M16 × 1.5
Flange tightening torque	2.5...7.3 Nm
Mechanical lifespan	> 100 Mating cycles
Pollution degree	3
Protection class	IP68 NEMA: 1, 3, 4, 6P
Number of cores	5
Conductor material	TC (tinned copper)
Core insulation	PVC
Core cross-section	5 x 14 AWG [Similar to 2.50 mm ²]
Core colors	BN, WH, BU, BK, GY
Electrical properties at +20 °C	
Rated voltage	63 V
Current	16 A

Features



■ M12-Stecker, L-codiert, 4-polig + FE

Contact assignment

Connector A

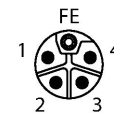

Circuit Diagram

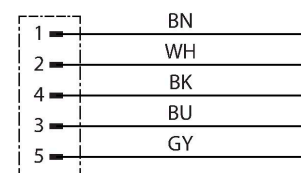

Technical data

Mechanical and chemical properties

Ambient temperature range (stationary) -40 °C...+85 °C

Approvals CE
UKCA

Note

**CAUTION: RISK OF ELECTRIC SHOCK!
DO NOT DISCONNECT UNDER LOAD!**

- We reserve the right to make technical modifications without prior notice.

Through bore

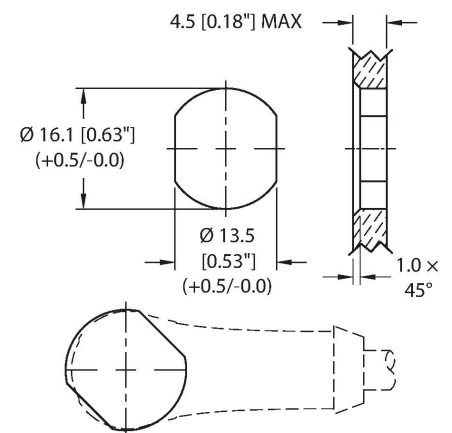

Threaded bore

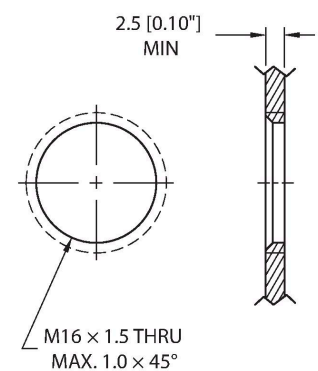

Front panel mounting

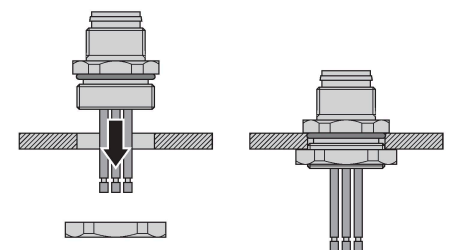

Derating curve

