

FKFD54PL-1/M16

M12 Power Flange – Rear-mounted

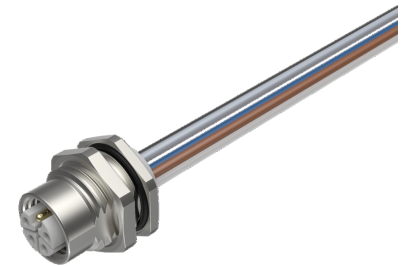
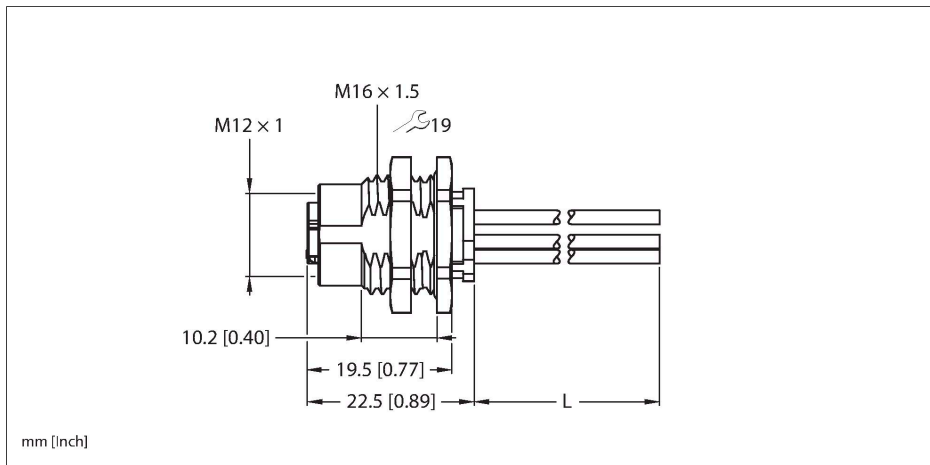

Technical data

Type	FKFD54PL-1/M16
ID	100028353
Connector A	Female, M12 × 1, L-coded
Design specification	acc. to IEC 61076-2-111
Number of Pins	4+FE
Contacts	Brass, CuZn, Gold-plated
Contact carriers	Plastic, PA, Black
Seal	O ring, Plastic, FKM/FPM
Flange housing	Brass, CuZn, Nickel-plated
Tightening torque (range)	0.4 ... 1 Nm (observe max. torque of mating connector!)
Mounting type	backplane mounting
Screw-in thread seal	O-ring, NBR
Screw-in thread	M16 × 1.5
Flange tightening torque	2.5...7.3 Nm
Mechanical lifespan	> 100 Mating cycles
Pollution degree	3
Protection class	IP68 NEMA: 1, 3, 4, 6P
Conductor data	
Cable length	1 m, (+ 50 mm or 4 % of the length/-0.0, depending on which value is larger)
Conductor material	TC (tinned copper)
Core insulation	PVC
Core cross-section	5 x 14 AWG [Similar to 2.50 mm ²]
Core colors	BN, WH, BU, BK, GY

Features



■ M12-Kupplung, L-codiert, 4-polig + FE

Contact assignment

Connector A

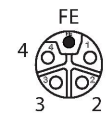

Circuit Diagram

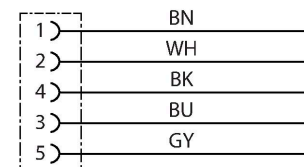

Technical data

Electrical properties at +20 °C

Rated voltage	63 V
Current	16 A

Mechanical and chemical properties

Ambient temperature range (stationary)	-40 °C...+85 °C
Approvals	CE UKCA

Note

**CAUTION: RISK OF ELECTRIC SHOCK!
DO NOT DISCONNECT UNDER LOAD!**

- We reserve the right to make technical modifications without prior notice.

Through bore

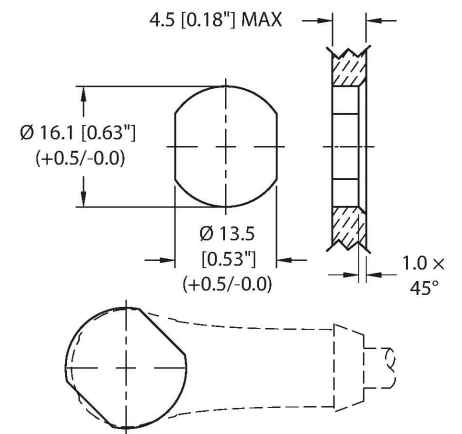

Threaded bore

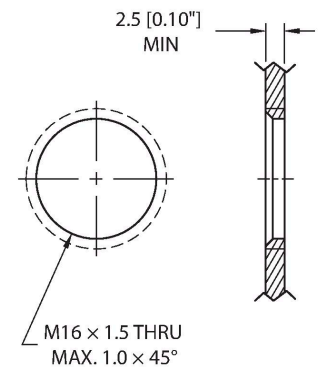

Rear-mounted

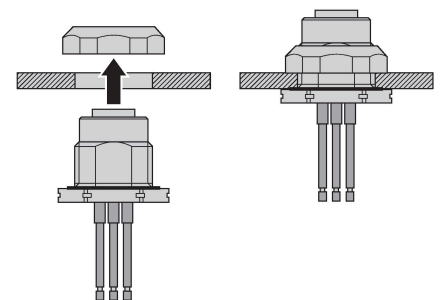

Derating curve

